

TruTech™
**ENGINEERED THERMOPLASTICS
AND FLUOROPOLYMERS**

TABLE OF CONTENTS

SUPERIOR MATERIAL PERFORMANCE 3

IN-HOUSE PROCESSING CAPABILITIES 4

QUALITY ASSURANCE 5

MATERIALS DEVELOPMENT 6

PTFE-BASED MATERIALS OVERVIEW 7

PEEK-BASED MATERIALS OVERVIEW 8

PPS AND POLYIMIDE MATERIALS OVERVIEW 9

MATERIAL DATA SHEETS

PTFE-Based Materials 10-30

PEEK-Based Materials 31-42

PPS and Polyimide Materials 43-46



SUPERIOR MATERIAL PERFORMANCE

Incorporating the latest advances in polymer science, TruTech™ materials from Cook Compression® provide superior durability and optimum performance characteristics for reciprocating compressor components, including packing rings, wiper rings, piston rings and rider rings.

The TruTech family includes custom PTFE, modified PTFE, UHMWPE, PEEK, PPS, polyimide and other high-temperature aromatic polymer materials. In-house precision blending capabilities enable Cook Compression to enhance specific material properties using reinforcements, fillers and additives such as glass fiber, carbon, carbon fiber, graphite, metal powders, FDA-approved minerals, and molybdenum disulphide (MoS₂). Special formulations provide high-performance sealing and lasting reliability for even the most demanding non-lubricated, dry-gas and high-temperature applications.

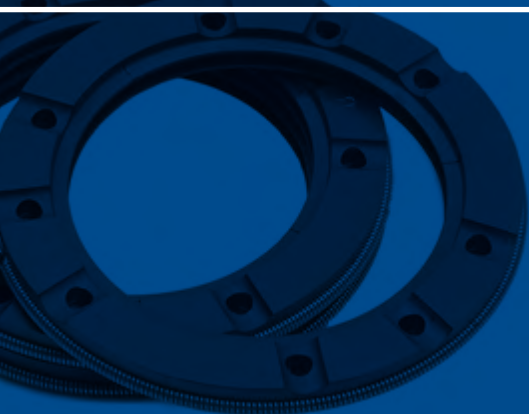
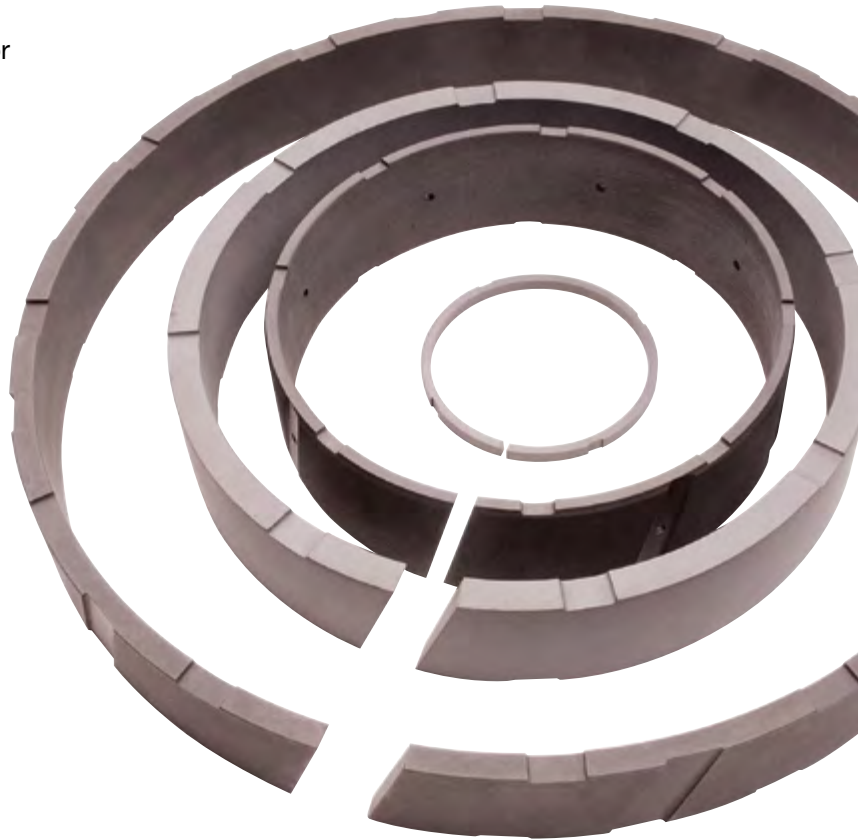

COMMON USES

Custom-blended TruTech thermoplastics and fluoropolymers are used in a broad range of industrial applications and equipment. Common uses include:

- Bearings
- Bellows
- Bushings
- Gaskets
- Impellers
- Piston rings
- Rod rings
- Seals
- Sleeves
- Spacers
- Valve seats
- Wear rings
- Wiper rings

IN-HOUSE PROCESSING CAPABILITIES

With complete in-house blending and processing capabilities, Cook Compression has the flexibility and expertise to deliver custom solutions tailored for maximum performance in your applications.

Compounding, compression molding, free sintering, injection molding and machining are all performed in-house and closely monitored to ensure the quality and consistency of finished products. Quality assurance procedures include full batch documentation and certificates of analysis.

We maintain an extensive inventory of tooling and can manufacture custom tooling to meet your requirements.

COLD COMPRESSION MOLDING AND FREE SINTERING

The free sintering process is primarily used with PTFE-based material formulations. Raw powder is mechanically blended in a controlled environment to produce a custom formulation. The blended powder is placed in a mold and subjected to a controlled pressure profile to produce a “green” pre-form. This pre-form is then placed in an oven where an engineered temperature profile is applied to consolidate the powder and optimize its bulk properties.

HOT COMPRESSION MOLDING

Hot compression molding is used for PEEK-based material formulations. As in the cold compression process, raw materials are mechanically blended in powder form and cold pressed in a mold. The mold is then transferred to an oven to be heated above the material melting point. Pressure is applied again to the melted material. Once the material is fully crystallized and consolidated under pressure, the part is removed from the mold and annealed to relieve internal stresses and maximize thermal and mechanical characteristics.

INJECTION MOLDING

Injection molding is primarily used with PEEK materials to form specified shapes. The material starts in the form of pellets, which are first dried, then melted. The melted material is injected at high pressure into a mold cavity to cool and harden. A holding pressure is applied to compensate for thermal shrinkage.

OUR CAPABILITIES

- PTFE, UHMWPE, PEEK, PPS and polyimide shapes
- Heavy cross-section molding
- Unfilled (virgin) and filled PTFE rod and tube
- Modified PTFE molding and welding
- Billets up to 8 in. (203 mm) length
- Solid rods up to 6 in. (152 mm) diameter
- Tubes up to 42 in. (1066 mm) outer diameter, with 2 in. (50 mm) wall thickness



QUALITY ASSURANCE

Cook Compression has developed a comprehensive quality control program to ensure materials and finished components meet the highest standards.

Every batch of material is documented for full traceability of raw materials, blending, processing, and inspection. Information is available upon request in the form of a certificate of analysis.

In addition, each step of production follows documented procedures so the quality level is repeated for every batch. Our process standards control blending, pressing, sintering, and melting, as well as secondary operations.

Manufactured basic shapes are inspected visually and dimensionally at the end of the manufacturing process to ensure they meet customer specifications.



MATERIALS DEVELOPMENT

The Dover Precision Components Materials Technology program integrates materials research with extensive engineering resources and more than a century of practical experience.

Our Materials Laboratory features state-of-the-art mechanical, chemical, optical and thermal analysis equipment, as well as advanced friction and wear testing, to help us develop next-generation polymeric materials, optimize process parameters and product quality, and perform failure analyses.

Our tools allow us to identify, differentiate and evaluate materials by their signature properties, such as:

- Filler ratios and composition
- Mechanical performance over a wide temperature and frequency range
- Coefficient of thermal expansion (CTE)
- Transition points (e.g., melting and glass transition temperatures)

New materials receive intensive laboratory analysis and undergo comprehensive testing before release to the field. The Materials Lab also ensures the ongoing quality and consistency of our raw materials.

FROM RAW MATERIAL TO PROVEN PRODUCT

Broad in-house research and development capabilities enable us to control development from material composition through manufacturing process and product testing.

The Materials Lab includes prototyping equipment for the replication and evaluation of manufacturing procedures in the lab environment. After a multifaceted analysis of material properties and assessment on in-house reciprocating wear testers, materials can be tested at product scale in a test compressor at the Dover Precision Components Innovation Lab.



PTFE-BASED MATERIALS

PTFE (polytetrafluoroethylene) materials are the most common type of material used in reciprocating compressor piston, rider and packing rings. Due to its unique molecular arrangement, PTFE has an extremely low coefficient of friction. Additionally, it is non-reactive with most common gases and liquids and has excellent chemical resistance. It can be continuously used at temperatures up to 250°C (490°F) and works well at extremely low (cryogenic) temperatures.

Reinforcing fillers, wear resistant additives and self-lubricating fillers are typically applied to enhance the properties of PTFE. Fillers are selected and combined to reduce wear and improve performance based on the specific operating environment.

Standard grade PTFE materials, using fillers such as glass fiber, MoS₂, graphite or carbon, provide good friction, wear and mechanical properties in lubricated and low severity non-lubricated service.

For more challenging conditions – higher temperatures, higher pressures and/or harsh chemicals – Cook Compression typically specifies upgraded PTFE material variants.

Bone-dry non-lubricated service, problem gases and other niche applications use specialty PTFEs with premium fillers, propriety formulations and propriety processing methods.



MATERIAL LIST

Standard PTFE Materials

- P1110
- P1120
- P1130
- P1140
- P1150
- P1160
- P1170
- P1210
- P1220

Upgrade PTFE Materials

- P2210
- P2220
- P2410
- P2420
- P2430
- P2510

Specialty PTFE Materials

- P3200
- P3210
- P3300
- P3310
- P3320
- P3330

PEEK-BASED MATERIALS

PEEK (polyetheretherketone) materials are the second most common type of material for piston, rider and packing rings and may also be specified for valve components in high-temperature environments. PEEK materials are generally stronger than PTFE materials.

PEEK, like PTFE, has broad resistance to most common chemicals in the oil & gas industry and is capable of running continuously at temperatures up to 250°C (490°F). While fillers are not always required with PEEK, they may be incorporated to enhance material performance for specific operating conditions. PTFE and other self-lubricants, such as graphite and MoS₂, are typically used to reduce the relatively higher coefficient of friction of PEEK. Reinforcing and wear resistant fillers may also be introduced to further improve mechanical and wear properties.

Standard grade PEEK materials are suitable for most lubricated compressor service, while upgraded PEEK materials provide more lubricity and higher strength.

Specialty grade PEEK materials from Cook Compression use premium fillers and proprietary formulations to meet the requirements of difficult applications, including non-lubricated dry gas service.



MATERIAL LIST

Standard PEEK Materials

- K1000
- K1030
- K1050

Upgrade PEEK Materials

- K2310
- K2330
- K2340

Specialty PEEK Materials

- K3400
- K3410
- K3420
- K3430
- K3510
- K3520

PPS AND POLYIMIDE MATERIALS

Cook Compression also produces specialty PPS (polyphenylene sulfide) and polyimide materials.

PPS mechanical and wear properties are similar to those of PEEK. PPS has broad chemical resistance and is capable of running continuously at temperatures up to 220°C (428°F). It is sometimes used as a filler to improve the wear performance of PTFE in piston, rider and packing rings.

Polyimides are typically reserved for extreme, high-temperature applications. Polyimides are resistant to most chemicals, except steam and ammonia, and exhibit excellent strength and wear resistance. PTFE and graphite are typically used as fillers to reduce the coefficient of friction.

MATERIAL LIST

- V3710
- V3720
- V3810
- V3820

VALVE MATERIALS

Depending on application requirements, Cook Compression uses filled and unfilled versions of PEEK, PPS and nylon for plastic valve components. Properties of the compressed gas, such as its chemistry, temperature and pressure, as well as application parameters of the compressor, such as its speed, determine the optimum material for each component.

Valve components are generally injection molded and then machined to tight tolerances.

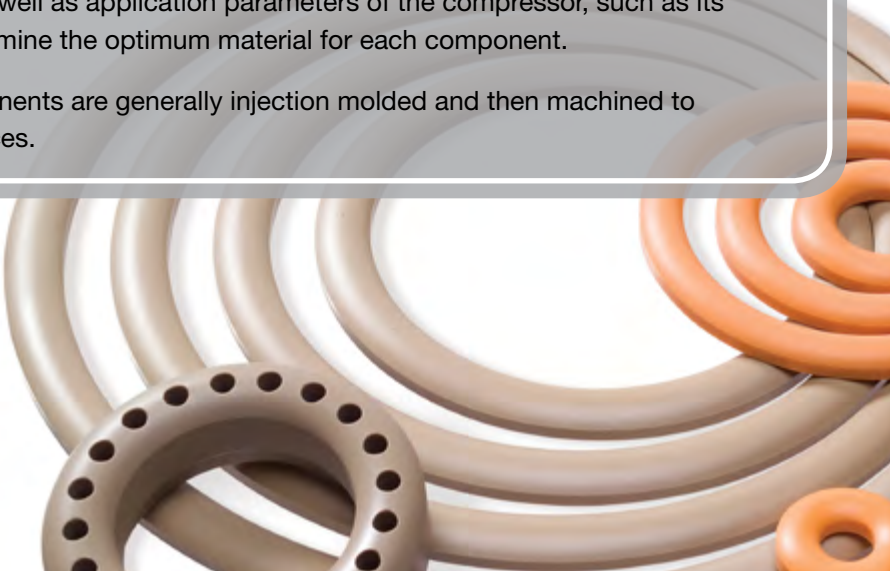

MATERIAL DATA SHEET



TruTech™ P1110

Cook Compression® developed TruTech P1110 material for the unique demands of oil wiper service. The innovative PTFE-based compound is engineered to provide a sharp wiping edge in wiper rings and retain that wiping edge over extended use. TruTech P1110 is also formulated to impart flexibility to wiper rings, allowing the material to tightly conform to the rod surface and eliminate potential leak paths.

TruTech P1110 delivers outstanding results in oil wiper packing and may be applied in any lubricated service where PTFE can be used. For some applications, TruTech P1110 may also be selected to enhance the performance of piston rings, rider rings, rod packing rings and bushings.

Property	Value		ASTM Method
Tensile Strength	2,700 psi	18.6 MPa	D1708
Elongation	125%		D1708
CTE*	$65 \times 10^{-6}/^{\circ}\text{F}$	$117 \times 10^{-6}/^{\circ}\text{C}$	E831
Hardness	65 Shore D		D2240
Specific Gravity	2.0		D792

* CTE – Coefficient of thermal expansion

MATERIAL DATA SHEET



TruTech™ P1120

TruTech P1120 is a compression-molded, glass and molybdenum disulphide filled PTFE material that is resistant to most chemicals. Suitable for use in piston rings, rider rings and rod rings.

Property	Value		ASTM Method
Tensile Strength	2,000 psi	13.8 MPa	D638
Elongation	280%		D638
CTE* – Radial	$4.4 \times 10^{-5}/^{\circ}\text{F}$	$8.0 \times 10^{-5}/^{\circ}\text{C}$	E831-03
CTE – Axial	$8.9 \times 10^{-5}/^{\circ}\text{F}$	$16.0 \times 10^{-5}/^{\circ}\text{C}$	E831-03
Density	0.082 lb/in ³	2.3 g/cm ³	D792

* CTE – Coefficient of thermal expansion

MATERIAL DATA SHEET



TruTech™ P1130

TruTech P1130 is a compression-molded, carbon and graphite filled PTFE material that is resistant to most chemicals. Suitable for use in piston rings, rider rings, rod rings and bushings.

Property	Value		ASTM Method
Tensile Strength	2,000 psi	13.8 MPa	D638
Elongation	60%		D638
CTE* – Radial	$4.9 \times 10^{-5}/^{\circ}\text{F}$	$8.8 \times 10^{-5}/^{\circ}\text{C}$	D696
CTE – Axial	$6.3 \times 10^{-5}/^{\circ}\text{F}$	$11.3 \times 10^{-5}/^{\circ}\text{C}$	D696
Density	0.080 lb/in ³	2.2 g/cm ³	D792

* CTE – Coefficient of thermal expansion

MATERIAL DATA SHEET



TruTech™ P1140

TruTech P1140 is a PTFE-based material with a selection of fillers that assists in increasing performance in lubricated or non-lubricated dry gas applications. It is a good cost-effective solution for a wide range of non-lubricated applications.

Property	Value		Method
Tensile Strength	2,320 psi	16.0 MPa	BS EN ISO 13000-2
Elongation	100%		BS EN ISO 13000-2
Hardness	68-73 Shore D		BS EN ISO 13000-2
Specific Gravity	2.10-2.14		BS EN ISO 13000-2

* CTE – Coefficient of thermal expansion

MATERIAL DATA SHEET



TruTech™ P1150

TruTech P1150 is a compression-molded, carbon and graphite filled PTFE material that is resistant to most chemicals and exhibits one of the lowest CTE values in this category. Suitable for use in piston rings, rider rings, rod rings and bushings where enhanced wear resistance is critical.

Property	Value		ASTM Method
Tensile Strength	2,200 psi	15.2 MPa	D638
Elongation	40%		D638
CTE* – Radial (up to 392°F/200°C)	4.1×10 ⁻⁵ /°F	7.4×10 ⁻⁵ /°C	D696
CTE – Axial (up to 392°F/200°C)	5.2×10 ⁻⁵ /°F	9.3×10 ⁻⁵ /°C	D696
Density	0.073 lb/in ³	2.02 g/cm ³	D792

* CTE – Coefficient of thermal expansion

MATERIAL DATA SHEET



TruTech™ P1160

TruTech P1160 is a carbon and graphite filled PTFE material.

Property	Value		ASTM Method
Tensile Strength	2,200 psi	15.2 MPa	D4745
Elongation	30%		D4745
Hardness	68/66 Shore D		D2240
CTE*, stress-relieved material, 78 to 500°F (25 to 260°C)	MD [†] 3.4137%	CD [‡] 2.5467%	E831-03
Density	0.072 lb/in ³	1.99 g/cm ³	D792-00

* CTE – Coefficient of thermal expansion

† MD – Properties measured parallel to the direction of molding;

‡ CD – Properties measured perpendicular to the direction of molding

MATERIAL DATA SHEET



TruTech™ P1170

TruTech P1170 is a glass fiber filled PTFE material.

Property	Value		ASTM Method
Tensile Strength	3,000 psi	20.7 MPa	D4745
Elongation	250%		D4745
Hardness	63/59 Shore D		D2240
CTE*, stress-relieved material, 78 to 500°F (25 to 260°C)	MD†	4.2280%	E831-03
	CD‡	2.9740%	
Density	0.079 lb/in ³	2.20 g/cm ³	D792-00

* CTE – Coefficient of thermal expansion

† MD – Properties measured parallel to the direction of molding;

‡ CD – Properties measured perpendicular to the direction of molding

MATERIAL DATA SHEET



TruTech™ P1210

TruTech P1210 is a blend of PTFE and bronze powder. Parts are machined from compression-molded tubes or rings which have been heat stabilized.

Property	Value		ASTM Method
Tensile Strength	1,700 psi	11.7 MPa	D638
Elongation	40%		D638
CTE* – Radial	$4.3 \times 10^{-5}/^{\circ}\text{F}$	$7.7 \times 10^{-5}/^{\circ}\text{C}$	D696
CTE – Axial	$5.7 \times 10^{-5}/^{\circ}\text{F}$	$10.3 \times 10^{-5}/^{\circ}\text{C}$	D696
Density	0.144 lb/in ³	3.986 g/cm ³	D792

* CTE – Coefficient of thermal expansion

MATERIAL DATA SHEET



TruTech™ P1220

TruTech P1220 is a blend of PTFE and bronze powder.

Property	Value		ASTM Method
Tensile Strength	4,200 psi	29.0 MPa	D4745
Elongation	290%		D4745
Hardness	65/62 Shore D		D2240
CTE*, stress-relieved material, 78 to 500°F (25 to 260°C)	MD†	4.1730%	E831-03
	CD‡	3.4636%	
Density	0.110 lb/in ³	3.05 g/cm ³	D792-00

* CTE – Coefficient of thermal expansion

† MD – Properties measured parallel to the direction of molding;

‡ CD – Properties measured perpendicular to the direction of molding

MATERIAL DATA SHEET



TruTech™ P2210

TruTech P2210 is a blend of proprietary fillers in a PTFE matrix, created for rod packing rings, piston rings and rider rings used in non-lubricated and/or high-temperature applications. It is uniquely suited for the demands of injection-stretch blow molding processes used to produce PET (polyethylene terephthalate). It also provides outstanding performance in a variety of other applications, both lubricated and non-lubricated.

TruTech P2210 was developed for non-lubricated applications up to 1,000 psi (70 bar) and lubricated applications up to 2,500 psi (175 bar). It has demonstrated exceptional wear behavior with air, methane, propane, LNG and bone dry gases.

Property	Value		ASTM Method
Tensile Strength	1,800 psi	12.4 MPa	D638
Elongation	130%		D638
CTE*	$68 \times 10^{-6}/^{\circ}\text{F}$	$122 \times 10^{-6}/^{\circ}\text{C}$	E831
Hardness	65 Shore D		D2240
Specific Gravity	3.9		D792

* CTE – Coefficient of thermal expansion

MATERIAL DATA SHEET



TruTech™ P2220

TruTech P2220 is a compression-molded PTFE alloy designed primarily for non-lubricated air compression. Suitable for piston and rider rings, rod rings, and bushings.

Property	Value		ASTM Method
Tensile Strength	2,000 psi	13.8 MPa	D638
Flexural Strength	1,600 psi	11.0 MPa	D790
Elongation	40%		D638
CTE* – Radial	$4.3 \times 10^{-5}/^{\circ}\text{F}$	$7.7 \times 10^{-5}/^{\circ}\text{C}$	D696
CTE – Axial	$5.7 \times 10^{-5}/^{\circ}\text{F}$	$10.3 \times 10^{-5}/^{\circ}\text{C}$	D696
Thermal Conductivity	.30 BTU/hr-ft-°F	.005 W/cm-°C	
Density	0.139 lb/in ³	3.8 g/cm ³	D792
Hardness	65 Shore D		D2240

* CTE – Coefficient of thermal expansion

MATERIAL DATA SHEET



TruTech™ P2410

TruTech P2410 is a blend of PTFE and polyimide.

Property	Value		ASTM Method
Tensile Strength	3,500 psi	24.1 MPa	D4745
Elongation	290%		D4745
Hardness	60/56 Shore D		D2240
CTE*, stress-relieved material, 78 to 500°F (25 to 260°C)	MD†	4.222%	E831-03
	CD‡	3.800%	
Density	0.070 lb/in ³	1.95 g/cm ³	D792-00

* CTE – Coefficient of thermal expansion

† MD – Properties measured parallel to the direction of molding;

‡ CD – Properties measured perpendicular to the direction of molding

MATERIAL DATA SHEET



TruTech™ P2420

TruTech P2420 is a filled PTFE alloy suitable for lubricated, non-lubricated and mini-lube applications. Suitable for use in piston and rider rings, rod rings, and bushings.

Property	Value		ASTM Method
Tensile Strength	1,600 psi	11.0 MPa	D638
Elongation	175%		D638
CTE*	$5.4 \times 10^{-5}/^{\circ}\text{F}$	$9.7 \times 10^{-5}/^{\circ}\text{C}$	D696
Density	0.070 lb/in ³	1.9 g/cm	D792

* CTE – Coefficient of thermal expansion

MATERIAL DATA SHEET



TruTech™ P2430

TruTech P2430 is a polyimide and graphite filled PTFE alloy.

Property	Value		ASTM Method
Tensile Strength	2,770 psi	19.1 MPa	D4745
Elongation	260%		D4745
Hardness	64 Shore D		D2240
Density	0.067 lb/in ³	1.85 g/cm ³	D792-00

MATERIAL DATA SHEET



TruTech™ P2510

TruTech P2510 is a proprietary polymer alloy developed for use in non-lubricated, dry gas applications, including bone-dry gases. The unique self-lubricating properties of this material also provide excellent wear resistance in very wet gas environments. Suitable for use in piston and rider rings, rod rings, and bushings.

Property	Value		ASTM Method
Tensile Strength	3,000 psi	20.7 MPa	D638
Elongation	15%		D638
Specific Gravity	2.0		D792
Hardness	62-65 Shore D		D2240

MATERIAL DATA SHEET



TruTech™ P3200

TruTech P3200 is a proprietary polymer alloy developed for use in non-lubricated, dry nitrogen compressors. The unique self-lubricating properties of this material provide exceptional wear resistance in this demanding application. Suitable for use in piston and rider rings, rod rings, and bushings.

Property	Value		ASTM Method
Tensile Strength	1,500 psi	10.3 MPa	D638
Elongation	5.0%		D638
CTE*	$4.6 \times 10^{-5}/^{\circ}\text{F}$	$8.3 \times 10^{-5}/^{\circ}\text{C}$	D696
Specific Gravity	2.0		D792
Hardness	65 Shore D		D2240

* CTE – Coefficient of thermal expansion

MATERIAL DATA SHEET



TruTech™ P3210

TruTech P3210 is a proprietary polymer alloy developed for use in non-lubricated, dry nitrogen compressors. The unique self-lubricating properties of this material provide exceptional wear resistance in this demanding application. Suitable for use in piston and rider rings, rod rings, and bushings.

Property	Value		ASTM Method
Tensile Strength	1,500 psi	10.3 MPa	D638
Elongation	5.0%		D638
CTE*	$4.6 \times 10^{-5}/^{\circ}\text{F}$	$8.3 \times 10^{-5}/^{\circ}\text{C}$	D696
Specific Gravity	2.0		D792
Hardness	65 Shore D		D2240

* CTE – Coefficient of thermal expansion

MATERIAL DATA SHEET



TruTech™ P3300

TruTech P3300 is a proprietary polymer alloy developed for use in non-lubricated, dry gas applications. Suitable for use in piston and rider rings, rod rings, and bushings.

Property	Value		ASTM Method
Tensile Strength	1,600 psi	11.0 MPa	D638
Elongation	5%		D638
CTE*	$5.0 \times 10^{-5}/^{\circ}\text{F}$	$9.0 \times 10^{-5}/^{\circ}\text{C}$	D696
Specific Gravity	1.8		D792
Hardness	65 Shore D		D2240

* CTE – Coefficient of thermal expansion

MATERIAL DATA SHEET



TruTech™ P3310

TruTech P3310 is an advanced second generation polymer which has been specially developed for non-lubricated operation in dry and bone-dry gases. It has been successfully used in ethylene, natural gas, methane and hydrogen. Suitable for use in cylinder rings and rod packing rings.

This material is not suitable for lubricated applications.

Property	Value	
Tensile Strength	1,700 psi	11.72 MPa
Maximum Operating Temperature	300°F	150°C
Elongation	5%	
CTE* – Radial	26×10 ⁻⁶ /°F	46×10 ⁻⁶ /°C
CTE – Axial	73×10 ⁻⁶ /°F	132×10 ⁻⁶ /°C
CTE – Tangential	20×10 ⁻⁶ /°F	36×10 ⁻⁶ /°C
CTE – Volumetric	73×10 ⁻⁶ /°F	132×10 ⁻⁶ /°C
Specific Gravity	1.8	
Hardness	67	

* CTE – Coefficient of thermal expansion

MATERIAL DATA SHEET



TruTech™ P3320

TruTech P3320 is a proprietary polymer alloy developed for use in non-lubricated, dry gas applications, including bone-dry gases. The unique self-lubricating properties of this material also provide excellent wear resistance in very wet gas environments. Suitable for use in piston and rider rings, rod rings, and bushings.

Property	Value		ASTM Method
Tensile Strength	1,600 psi	11.0 MPa	D638
Elongation	5.0%		D638
CTE*	$5.0 \times 10^{-5}/^{\circ}\text{F}$	$9.0 \times 10^{-5}/^{\circ}\text{C}$	D696
Specific Gravity	1.8		D792
Hardness	65 Shore D		D2240

* CTE – Coefficient of thermal expansion

MATERIAL DATA SHEET



TruTech™ P3330

TruTech P3330 is a proprietary polymer alloy developed to extend sealing component life in non-lubricated gas compressors. It is formulated to be especially effective in bone-dry (extreme low dew point) applications, but can also offer excellent results in wet service. It has been successfully used in hydrocarbon mixtures, natural gas, ammonia and ethylene.

Suitable for use in packing rings, piston rings, rider rings and bushings.

Property	Value		ASTM Method
Tensile Strength at 68°F (20°C)	1,600 psi	11.0 MPa	D1708
Elongation at 68°F	5%		D1708
CTE*	45×10 ⁻⁶ /°F	81×10 ⁻⁶ /°C	E831
Hardness	65-70 Shore D		D2240
Specific Gravity	1.9		D792

* CTE – Coefficient of thermal expansion

MATERIAL DATA SHEET



TruTech™ K1000

TruTech K1000 is a thermoplastic with a base resin of PEEK. It is injection molded and stress relieved for dimensional stability. Parts are typically machined from molded tubes or discs.

TruTech K1000 was developed for conformability, dimensional stability and low wear in poorly lubricated service. It is resistant to most chemicals and acids and has a high resistance to hot water.

It is particularly suited to rings where stable edges must be maintained for effective sealing or wiping.

Property	Value	
Tensile Strength	13,000 psi	89.6 MPa
Flexural Strength	24,700 psi	170.3 MPa
Elongation	35%	
CTE*	3.0×10 ⁻⁵ /°F	5.4×10 ⁻⁵ /°C
Specific Gravity	1.32	

Temperature Limits	Value	
For Minimum Wear	300°F	149°C
Deflection Temperature at 265 psi	265°F	129°C
Melting Point	640°F	338°C
Zero Weight Loss in Air	500°F	260°C

* CTE – Coefficient of thermal expansion

MATERIAL DATA SHEET



TruTech™ K1030

TruTech K1030 is a carbon fiber filled PEEK alloy developed for extreme service in lubricated compressors. It provides high strength and abrasion resistance.

Property	Value		ASTM Method
Tensile Strength	21,960 psi	151.4 MPa	D638
Flexural Strength	32,610 psi	224.8 MPa	D790
Elongation	2.0%		D638
CTE*	$1.0 \times 10^{-5}/^{\circ}\text{F}$	$1.8 \times 10^{-5}/^{\circ}\text{C}$	D696
Density	0.052 lb/in ³	1.439 g/cm ³	D792

* CTE – Coefficient of thermal expansion

MATERIAL DATA SHEET



TruTech™ K1050

TruTech K1050 is a thermoplastic with a base resin of PEEK reinforced with glass fibers. Parts are machined from molded tube or discs. This material is primarily used in valve plates.

Properties	Value		ASTM Method
Tensile Strength	13,000 psi	89.6 MPa	D638
Elongation	1.50%		D638
CTE* – Axial	$2.3 \times 10^{-5}/^{\circ}\text{F}$	$4.1 \times 10^{-5}/^{\circ}\text{C}$	E831-03
CTE – Radial	$2.6 \times 10^{-5}/^{\circ}\text{F}$	$4.7 \times 10^{-5}/^{\circ}\text{C}$	E831-03
Density	0.054 lb/in ³	1.53 g/cm ³	D792

* CTE – Coefficient of thermal expansion

MATERIAL DATA SHEET



TruTech™ K2310

TruTech K2310 is a thermoplastic with a base resin of PEEK reinforced with graphite and PTFE.

Property	Value		ASTM Method
Tensile Strength	10,000 psi	68.9 MPa	D638 type 1
Elongation	1.70 %		D638 type 1
Initial Hardness	84 Shore D		D2240
Flexural Strength at 73°F (23°C)	15,415 psi	106.3 MPa	D790
Flexural Modulus of Elasticity at 73°F (23°C)	560,255 psi	3862.8 MPa	D790
Compressive Strength	20,242 psi	139.6 MPa	D695
Compressive Modulus	382.4852 psi	2.64 MPa	D695
CTE*, stress-relieved			
25-100°C Below Tg	MD [†]	48.70 μm/(m°C)	E831-03
	CD [‡]	48.90 μm/(m°C)	
25-150°C Above Tg	MD	80.33 μm/(m°C)	E831-03
	CD	82.06 μm/(m°C)	
25-250°C Above Tg	MD	151.33 μm/(m°C)	E831-03
	CD	153.00 μm/(m°C)	
Density	0.051 lb/in ³	1.40 g/cm ³	D792-00

* CTE – Coefficient of thermal expansion

† MD – Properties measured parallel to the direction of molding;

‡ CD – Properties measured perpendicular to the direction of molding

MATERIAL DATA SHEET



TruTech™ K2330

TruTech K2330 is a proprietary, injection- or compression-molded PEEK alloy developed for high temperature or poorly lubricated service. It can be run non-lubricated under the right conditions. For use primarily in packing rings and bushings because of size limitations.

Properties	Value		ASTM Method
Tensile Strength	6,700 psi	46.2 MPa	D638
Flexural Strength	16,500 psi	114 MPa	D790
CTE*	$1.5 \times 10^{-5}/^{\circ}\text{F}$	$2.7 \times 10^{-5}/^{\circ}\text{C}$	D696
Density	0.054 lb/in ³	1.5 g/cm ³	D792

* CTE – Coefficient of thermal expansion

MATERIAL DATA SHEET



TruTech™ K2340

TruTech K2340 is an injection-molded PEEK alloy for general purpose use in lubricated compressors where high strength and wear resistance are required. It is resistant to most chemicals except chlorine. For use primarily in packing rings and bushings because of size limitations.

Properties	Value		ASTM Method
Tensile Strength	11,000 psi	75.8 MPa	D638
Flexural Strength	19,000 psi	131 MPa	D790
Elongation	4.0%		D638
CTE*	$1.5 \times 10^{-5}/^{\circ}\text{F}$	$2.7 \times 10^{-5}/^{\circ}\text{C}$	D696
Density	0.047 lb/in ³	1.3 g/cm ³	D792
Hardness	81.0 Shore D		D2240

* CTE – Coefficient of thermal expansion

MATERIAL DATA SHEET



TruTech™ K3400

TruTech K3400 is a PEEK-based polymer alloy developed for extreme service in both lubricated and oil-free gas compressors. The unique self-lubricating properties of TruTech K3400 allow its successful use in piston, rider and rod rings for high-pressure oil-free compressors, including those handling bone-dry gases.

Properties	Value		ASTM Method
Tensile Strength	5,000 psi	34.4 MPa	D638
Elongation	1.0%		D638
CTE*	$2.2 \times 10^{-5}/^{\circ}\text{F}$	$4.0 \times 10^{-5}/^{\circ}\text{C}$	D696
Density	0.054 lb/in ³	1.5 g/cm ³	D792
Hardness	80 Shore D		D2240

* CTE – Coefficient of thermal expansion

MATERIAL DATA SHEET



TruTech™ K3410

TruTech K3410 is a proprietary polymer alloy of PEEK blended with reinforcing and lubricating fillers. It is a high-strength alloy developed for use in non-lubricated, dry gas service where additional wear resistance is required. Operational experience in medium- to high-pressure, non-lube hydrocarbon service suggests low wear rates compared to filled PTFE materials.

Properties	Value		ASTM Method
Tensile Strength	12×10 ³ psi	82.7 MPa	D638
Flexural Strength	17×10 ³ psi	117.2 MPa	D790
Shear Strength	7.7×10 ³ psi	53.1 MPa	D732
Flexural Modulus	1.5×10 ⁶ psi	10,342 MPa	D790
Elongation	4.0%		D638
CTE*	1.5×10 ⁻⁵ /°F	2.7×10 ⁻⁵ /°C	D696
Density	0.047 lb/in ³	1.3 g/cm ³	D792
Hardness	65 Shore D		D2240

* CTE – Coefficient of thermal expansion

MATERIAL DATA SHEET



TruTech™ K3420

TruTech K3420 is a hot-compression-molded PEEK alloy for general purpose use in lubricated compressors where high strength and wear resistance are required. It is resistant to most chemicals except chlorine. Suitable for use in piston rings, rider rings, packing rings and bushings.

Properties	Value		ASTM Method
Tensile Strength	8,700 psi	60.0 MPa	D638
Flexural Strength	16,000 psi	110 MPa	D790
Elongation	4.0%		D638
CTE*	$1.5 \times 10^{-5}/^{\circ}\text{F}$	$2.7 \times 10^{-5}/^{\circ}\text{C}$	D696
Density	0.049 lb/in ³	1.4 g/cm ³	D792
Hardness	82.0 Shore D		D2240

* CTE – Coefficient of thermal expansion

MATERIAL DATA SHEET



TruTech™ K3430

TruTech K3430 is a hot-compression-molded PEEK alloy for extreme service in lubricated compressors. It provides high strength and abrasion resistance.

TruTech K3430 was developed for abrasion resistance and low wear in poorly lubricated service. It is resistant to most chemicals and acids and has high resistance to hot water. It is a preferred material grade for rod rings in high-pressure, high-temperature lubricated service.

Properties	Value		ASTM Method
Tensile Strength	26,000 psi	179 MPa	D638
Flexural Strength	24,700 psi	170 MPa	D790
Elongation	2.0%		D638
CTE*	$1.6 \times 10^{-5}/^{\circ}\text{F}$	$2.9 \times 10^{-5}/^{\circ}\text{C}$	D696
Density	0.05 lb/in ³	1.4 g/cm ³	D792

* CTE – Coefficient of thermal expansion

MATERIAL DATA SHEET



TruTech™ K3510

TruTech K3510 is a filled PEEK alloy developed for higher temperature or poorly lubricated service. Suitable for use in piston and rider rings, rod rings, and bushings.

Properties	Value		ASTM Method
Tensile Strength	8,000 psi	55.2 MPa	D638
Flexural Strength	12,000 psi	82.7 MPa	D790
CTE*	$1.7 \times 10^{-5}/^{\circ}\text{F}$	$3.1 \times 10^{-5}/^{\circ}\text{C}$	D696
Density	0.054 lb/in ³	1.5 g/cm ³	D792

* CTE – Coefficient of thermal expansion

MATERIAL DATA SHEET



TruTech™ K3520

TruTech K3520 is a PEEK-based compression-molded alloy developed for extreme service in both lubricated and oil-free air compressors.

Properties	Value		ASTM Method
Tensile Strength	8,500 psi	58.6 MPa	D638
Elongation	2.8%		D638
CTE*	$3.4 \times 10^{-5}/^{\circ}\text{F}$	$6.1 \times 10^{-5}/^{\circ}\text{C}$	D696
Specific Gravity	2.2		D792
Hardness	87 Shore D		D2240

* CTE – Coefficient of thermal expansion

MATERIAL DATA SHEET



TruTech™ V3710

TruTech V3710 is a filled polyimide developed for extreme service applications. Parts are hot compression molded, then machined to size. It is resistant to most chemicals except steam and ammonia. Suitable for use in piston and rider rings, rod rings, and bushings.

Properties	Value		ASTM Method
Tensile Strength	9,500 psi	65.5 MPa	D638
Flexural Strength	16,500 psi	114 MPa	D790
Shear Strength	11,200 psi	77.2 MPa	D732
CTE*	$2.7 \times 10^{-5}/^{\circ}\text{F}$	$4.9 \times 10^{-5}/^{\circ}\text{C}$	D696
Density	0.054 lb/in ³	1.5 g/cm ³	D792
Thermal Conductivity	.50 BTU/hr-ft-°F	.009 W/cm-°C	D5930

* CTE – Coefficient of thermal expansion

MATERIAL DATA SHEET



TruTech™ V3720

TruTech V3720 is a hot-compression-molded, bearing-grade polyamide-imide filled with PTFE and graphite. It is resistant to most chemicals except steam and ammonia. Suitable for use in packing, piston and rider rings.

Properties	Value		ASTM Method
Tensile Strength	10.2×10 ³ psi	70.3 MPa	D638
Flexural Strength	13.1×10 ³ psi	90.3 MPa	D790
Elongation	2.8%		D638
Specific Gravity	1.46		D792

MATERIAL DATA SHEET



TruTech™ V3810

TruTech V3810 is an injection-molded, bearing-grade polyamide-imide filled with PTFE and graphite. It is resistant to most chemicals except steam and ammonia. Suitable for use in rod rings and bushings.

Properties	Value		ASTM Method
Tensile Strength	22,000 psi	151.7 MPa	D638
Flexural Strength	30,200 psi	208.2 MPa	D790
Compressive Strength	17,800 psi	122.7 MPa	D695
Elongation	7%		D638
CTE*	1.4×10 ⁻⁵ /°F	2.52×10 ⁻⁵ /°C	D696
Density	0.052 lb/in ³	1.44 g/cm ³	D792

* CTE – Coefficient of thermal expansion

MATERIAL DATA SHEET



TruTech™ V3820

TruTech V3820 is a compression-molded, bearing-grade polyamide-imide filled with PTFE and graphite. It is resistant to most chemicals except steam and ammonia. Suitable for use in packing, piston and rider rings.

Properties	Value		ASTM Method
Tensile Strength	10.5×10 ³ psi	72.4 MPa	D638
Flexural Strength	16.5×10 ³ psi	113.8 MPa	D790
Elongation	3%		D638
Density	0.052 lb/in ³	1.44 g/cm ³	D792

WHO WE ARE

Cook Compression is part of Dover Precision Components, an integrated provider of performance-critical solutions for rotating and reciprocating machinery across the oil & gas, power generation, marine, industrial, chemical and general processing markets.



Comprising the Waukesha Bearings®, Bearings Plus®, Inpro/Seal® and Cook Compression® brands, the Dover Precision Components portfolio includes hydrodynamic bearings, active magnetic bearings, system and bearing protection, and reciprocating compressor components. Each solution is custom-engineered to provide optimum efficiency, reliability and productivity, and backed by comprehensive aftermarket services.

Dover Precision Components serves its global customer base through facilities in North America, Europe, Asia and the Middle East, as well as technical sales representatives around the world.

READY TO GET STARTED?

Visit www.cookcompression.com to find your local Cook Compression representative or submit an inquiry.



COOK[®]
COMPRESSION

DOVER[®]
PRECISION
COMPONENTS

www.cookcompression.com | info-cook@doverprecision.com